

Stomp ACE ROTORUS

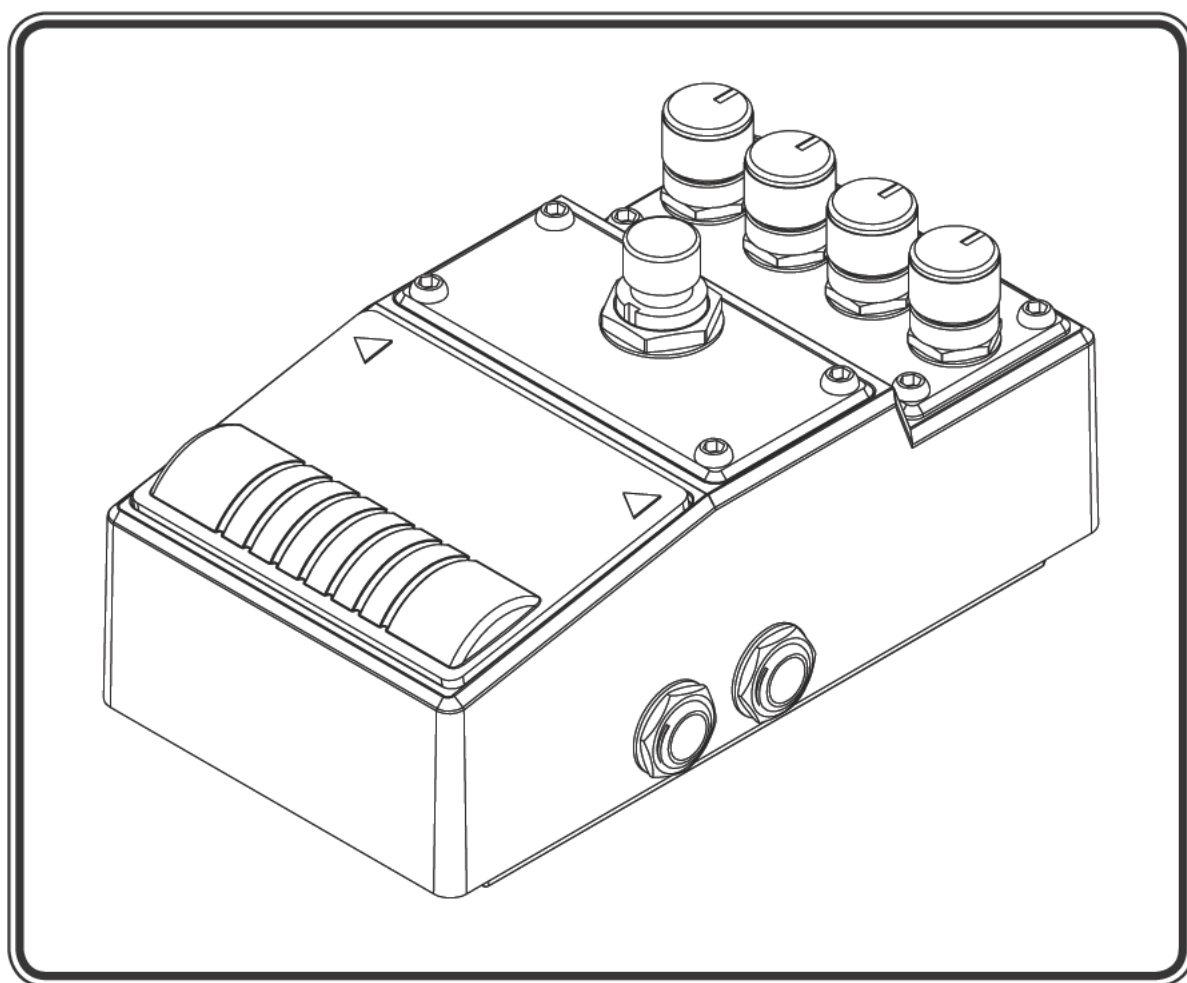

User's Manual



Ver. 1.00

Stomp ACE

1. Top Panel Controls

POS controls the binaural pan position. POS works differently depending on the Rotorus effect type used by the preset (p.4).

D.TIME controls delay time (ms).

DEPTH controls the depth of modulation applied to the delay.

PRESET switches between four preset slots: A, B, C, D (p.5).

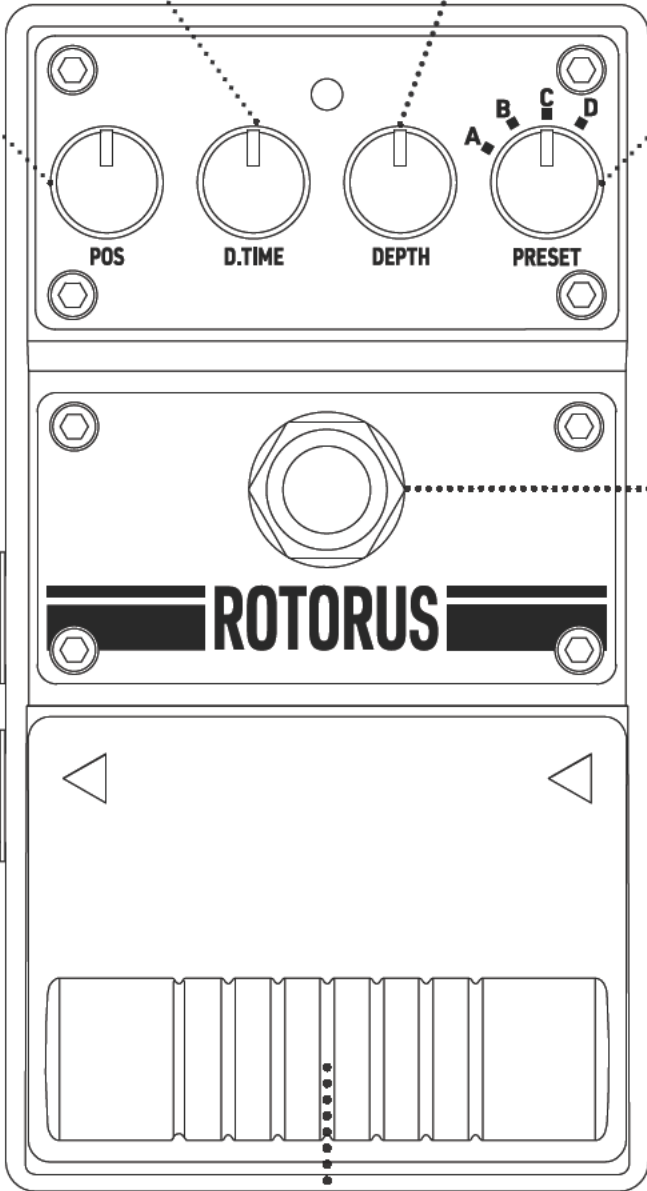

MAIN SWITCH - turns the effect ON/OFF. Press the switch in combination with the MORPH PAD to set the 'EFFECT MORPH' (p.6).

L (MONO) OUTPUT jack terminal.

L (MONO) INPUT jack terminal.

R OUTPUT jack terminal.

R INPUT jack terminal.

The **MORPH PAD** is a pressure-sensitive pad control used to 'morph' or change the effect between two different settings for POS, D.TIME, and DEPTH (p.6).

Stomp ACE

2. Rear Panel

USB micro-B input terminal. Enables Stomp ACE connection to a computer for preset programming and firmware upgrades. The pedal can also operate on USB bus power. A 5V, 1A power supply or greater is recommended.

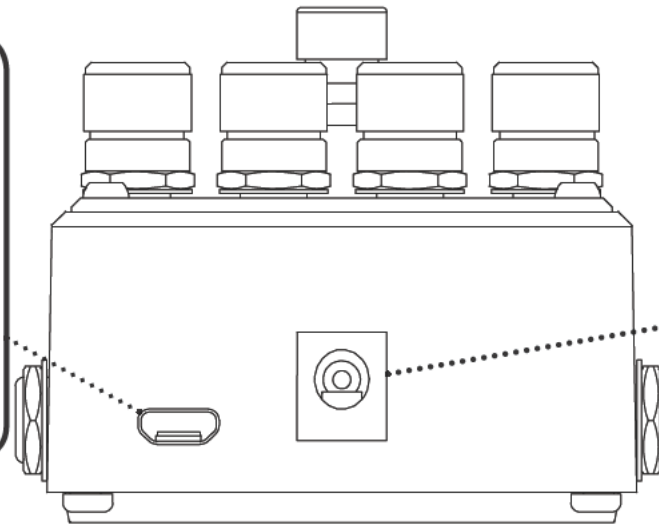

POWER DC IN. This terminal is used to connect an AC adapter. A standard 9V +/- polarity adapter for guitar pedals can be used.

Rating: 5V to 15V, 250mA or greater. The plug's center pin size is 2.1mm.

3. Basic Operation

- Connect the AC adapter to the DC IN or USB bus power to the USB connector.
- Turn down the volume on the amplifier before connecting your instrument and effects.
- This Stomp ACE pedal will power on when the L(MONO) INPUT is connected, and is ready to use after the LED color sequence lights 'red-green-blue'.
- Press the MAIN SWITCH to turn the effect ON/OFF. The LED on the top panel will light to indicate the effect is on.
- When the EFFECT MORPH is set (p.6), the effect sound can be changed gradually by applying pressure to the MORPH PAD. The EFFECT MORPH is not set by default.

4. Specifications

- Controls: POS, D.TIME, DEPTH, PRESET (A, B, C, D).
- Terminals: 1 x USB micro B, 1 x POWER DC IN, 4 x 1/4" Jacks = L (mono) / R INPUT, L (mono) / R OUTPUT.
- Power Requirements: 5~15V 250 mA DC, or USB micro-B 5V (1A or more is recommended).
- Max Input Level: 5 dBV.
- Input Impedance: 1 MΩ.
- Max Output Level: 5 dBV.
- Output Impedance: 1 kΩ.
- Dimensions: (H x W x D): 57 x 72 x 119 mm / 2.24" x 2.83" x 4.68".
- Weight: 360 g / 0.8 lb.

In the interest of product improvement, the specifications and/or appearance of this unit are subject to change without prior notice.

Stomp ACE

5. Effect Controls

Stomp ACE ROTORUS is a true dual-channel stereo binaural processor pedal that enables the sound to be panned in a 360 degree binaural stereo field.

Using the EFFECT MORPH function, you can articulate dynamic effect changes while playing, such as changing the sound's pan position or revolution speed.

- Turn the the **POS** knob to adjust the binaural panning position of the sound. POS controls different parameters depending on the type of Rotorus effect used by the preset.
- Turn the **D.TIME** (delay time) knob to adjust the value of a short delay (0 - 500 ms).
- Turn the **DEPTH** knob to adjust the depth of LFO modulation applied to the delay.
- Turn the **PRESET** knob to switch between the four effect presets loaded in slots A, B, C, D.

POS Function:

The POS knob controls panning position in different ways depending on the preset. The table below shows the specific function of the POS control for each preset.

ROTORUS Preset	POS Function
[A] ROTATION	POS controls the revolution speed (rpm) of the sound rotating around the 360 degree binaural stereo field.
[B] FIXED	POS controls the 'Azimuth' - the pan position of the sound in a 360 degree binaural stereo field.
[C] DOUBLE 1	POS controls the spread of two sounds that are opposite panned in the 360 degree binaural stereo field.
[D] DOUBLE 2	POS controls the spread of two sounds that are opposite panned in the 360 degree binaural stereo field. The dry signal's position is fixed at the center of the stereo field.

Stomp ACE

6. Presets

A 'Preset' stores all the settings of an effect. Stomp ACE ROTORUS is preloaded with four factory presets:

[A] ROTATION	<p>This preset can be used to create some really interesting rotation effects. The L and R input signals are mixed and sent to one binaural processor. The sound can be pan-rotated around the binaural stereo field in an anti-clockwise direction.</p> <p>POS controls the revolution speed (rpm) of the sound pan-rotating around the 360 degree binaural stereo field. The range of POS is 1 - 600 rpm.</p>
[B] FIXED	<p>This preset is used to set the panning of the sound at one perceived position in the binaural stereo field. The L and R input signals are mixed and sent to one binaural processor. The sound can be panned around the binaural stereo field in both directions.</p> <p>POS controls the 'Azimuth' - the pan position of the sound in a 360 degree binaural stereo field.</p>
[C] DOUBLE 1	<p>This preset creates a 'doubling' effect by using two binaural processors to opposite pan the L and R input signals. This preset can be used to open up or narrow the binaural stereo field. Delay processing is enabled for the right channel only.</p> <p>POS Controls the spread of two sounds that are opposite panned in the 360 degree binaural stereo field.</p>
[D] DOUBLE 2	<p>This preset creates a triple position 'doubling' effect by using two binaural processors to opposite pan the L and R input signals in the same way as [C] DOUBLE 1, but with the dry signal added at the center position. Delay processing is enabled for the left and right channels.</p> <p>POS Controls the spread of two sounds that are opposite panned in the 360 degree binaural stereo field.</p>

Loading Presets

The **Stomp ACE Updater** application loads new preset data into slots A, B, C, D. The updater software (Windows, Mac OS), preset data, along with instructions for loading presets are all available on our website.

The available Stomp ACE ROTORUS presets use different rotorus types and deeper parameter settings to expand the sonic possibilities!

Stomp ACE

7. Effect Morph

Stomp ACE ROTORUS is equipped with a pressure-sensitive pad control (MORPH PAD) that is used to 'morph' or transition between two different effect settings. This function is called **EFFECT MORPH**.

To use EFFECT MORPH, selected knobs (POS, D.TIME, DEPTH) are first set to 'target value' positions that correspond to maximum pad pressure. The 'start value' knob positions that correspond to zero pad pressure can be above or below the target values. This function allows you to create complex effect setting morphs that are instantly remapped when making further knob adjustments.

To enter the **EFFECT MORPH Setting Mode**:

1. Press the MAIN SWITCH in for 2 seconds while applying pressure to the MORPH PAD.
2. The LED flashes blue to indicate EFFECT MORPH Setting Mode.
3. Adjust the knobs (POS, D.TIME, DEPTH) to target positions (pressure = max). If you do not touch a knob then its value will not be mapped to MORPH PAD control.
4. To exit EFFECT MORPH Setting Mode press the MAIN SWITCH once.
5. Reset the knobs to start positions for the effect morph (pressure = 0).
6. Now when pressure is applied to the MORPH PAD, the LED turns blue and you will hear the effect change.

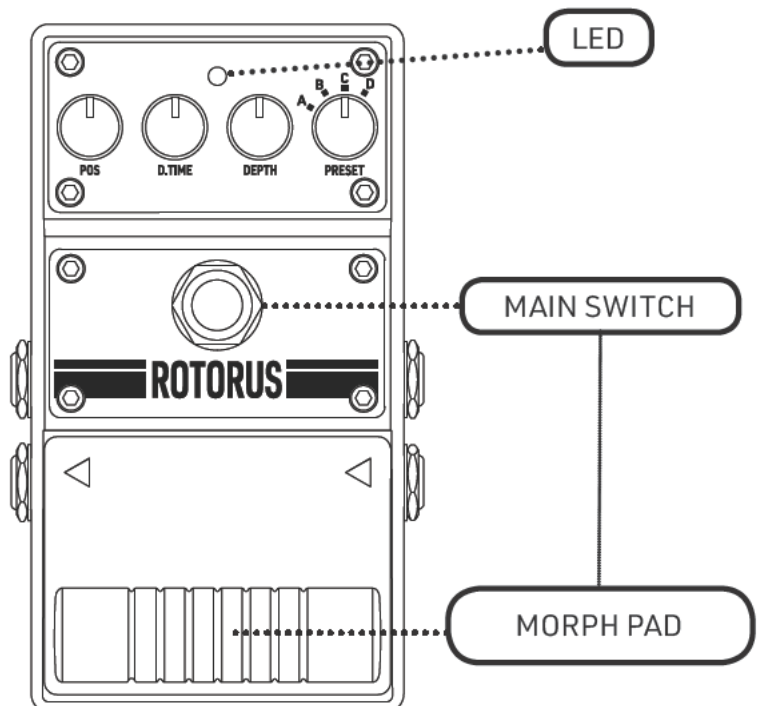

- Repeat steps 1. to 4. to set new target positions for an existing effect morph.
- Entering and exiting the EFFECT MORPH Setting Mode without touching any knobs will clear (delete) the current effect morph settings.
- Effect morph settings remain stored in internal memory when the pedal is turned off, and will be restored automatically when the pedal is turned on again.

8. Safety Precautions



Warning

This symbol indicates a hazard that could result in death or serious injury.

Never try to disassemble, or modify the unit.

Do not use or store in the following locations:

- Locations of high temperature (such as direct sunlight, near heating equipment).
- Moist or humid locations (near a bath or shower, or on a wet floor).
- Locations subject to salt damage.
- Locations subject to water or rain.
- Excessively dusty or sandy locations.

Do not apply too much pressure or tension or place a heavy object on the power cord. Doing so may damage the power cord and create a danger of fire or electrical shock.

Turn off the unit and unplug the AC adapter from the outlet and contact your local dealer or the manufacturer for repair in the case of any of the following:

- If the AC adapter, power cord, or plug is damaged.
- If smoke is emitted or an abnormal odor is noticed.
- If liquid or a foreign object enters the unit.
- If an abnormality or malfunction occurs in the unit.

Disconnect the power plug from the AC outlet if not using the unit for an extended period, or if lightning is expected. Failure to do so may cause electric shock, fire, or malfunction.

Never unplug the AC adapter while your hands are wet.

Do not disturb the heat radiation from the AC adapter. Built-up heat can deform the case or cause a fire hazard.

Be sure to use an AC adapter within the rated range.

* "AC adapter" includes power supplied via USB.

FCC COMPLIANCE

This device complies with part 15 of the FCC rules.

Operation is subject to the following two conditions:

1. This device may not cause harmful interference, and
2. This device must accept any interference received, including interference that may cause undesired operation.

For customers in Canada, this Class B digital apparatus complies with CAN ICES-3B/NMB-3(B).

8. Safety Precautions (Cont.)



This symbol indicates that in EU countries, this product must be collected separately from household waste, as defined in each region.

Products bearing this symbol must not be discarded together with household waste.

9. Use Precautions

Cleaning:

Do not use solvents (such as benzene, paint thinner) on the unit, since these may dull the finish or damage the surface.

Power:

Stomp ACE can use an AC adapter with a standard plug whose center pin is $\Phi 2.1$ mm.

Supports both center plus (+) and center minus (-) polarities.

Voltage and current ratings are within 5 to 15 VDC, 250 mA or more.

Power can also be supplied from the USB micro-B connector.

A 5V 1A or greater power supply is recommended.

Precautions When Connecting:

- To prevent malfunction and equipment failure, always turn down the volume, and turn off all the devices before making any connections.
- Once the connections have been completed, turn on the power to your various devices in the order specified. By turning on devices in the wrong order, you risk causing malfunctions and/or damage to speakers and other devices.

When powering up: Turn on the power to your guitar amp last.

When powering down: Turn off the power to your guitar amp first.

- This unit is equipped with a protection circuit. A brief interval (a few seconds) after power up is required before the unit will operate normally.
- Turn off the unit and unplug the AC adapter if an abnormality or malfunction occurs, and contact the dealer or the manufacturer.